

1

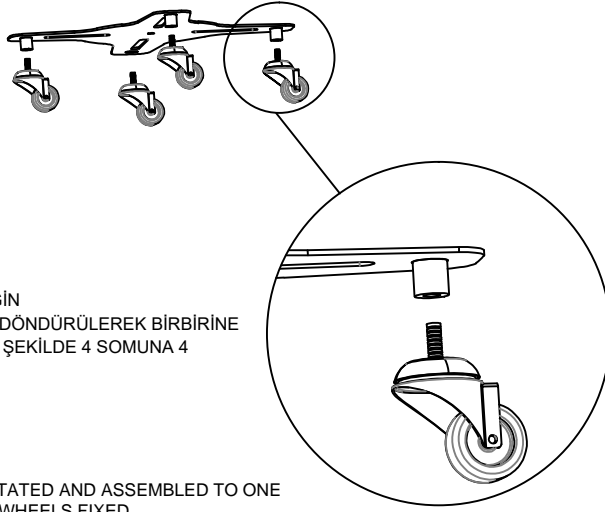

AYAK PARÇANIN ALTINDA  
BULUNAN SOMUN İLE TEKERLEĞİN  
ÜSTÜNDE YER ALAN CİVATANIN DÖNDÜRÜLEREK BİRBİRİNE  
MONTAJI GERÇEKLEŞTİRİLİR BU ŞEKİLDE 4 SOMUNA 4  
TEKERLEK SABİTLENİR

FOOT UNDER THE PIECE  
WITH THE NUT AND THE WHEEL  
THE BOLT WHICH IS ON IT IS ROTATED AND ASSEMBLED TO ONE  
TOGETHER THROUGH 4 NUTS 4 WHEELS FIXED

2

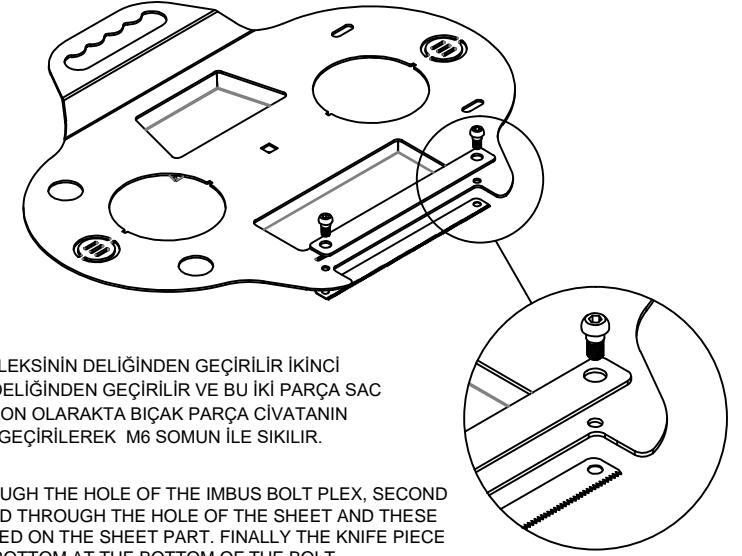

M 6 X 15 İMBUS CİVATA PLEKSİNİN DELİĞİNDEN GEÇİRİLİR İKİNCİ  
OLARAK CİVATA SACIN DELİĞİNDEN GEÇİRİLİR VE BU İKİ PARÇA SAC  
PARÇAYA OTURTULUR SON OLARAKTA BIÇAK PARÇA CİVATANIN  
ALTTA KALAN UCUNDAN GEÇİRİLEREK M6 SOMUN İLE SIKILIR.

M 6 X 15 IS PASSED THROUGH THE HOLE OF THE IMBUS BOLT PLEX, SECOND  
THAT THE BOLT IS PASSED THROUGH THE HOLE OF THE SHEET AND THESE  
TWO PIECES ARE INSERTED ON THE SHEET PART. FINALLY THE KNIFE PIECE  
THROUGH THE BOTTOM BOTTOM AT THE BOTTOM OF THE BOLT.

3

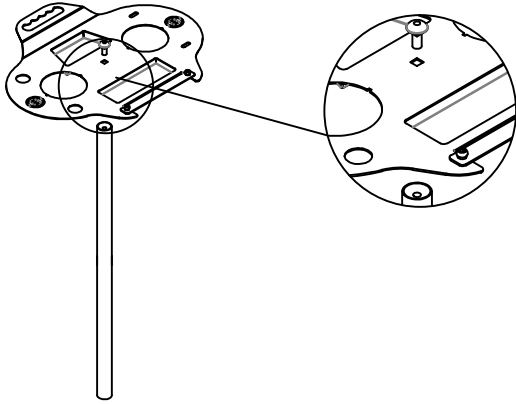

M6 X 30 KASA CİVATA ÜST SACIN KARE BOŞLUĞUNDAN GEÇİRİLİP  
BORUNUN İÇİNDE KAYNAKLI BULUNAN BURCA SIKILIR

M6 X 30 FRAME BOLT UPPER SHEET  
PASSING THROUGH THE SQUARE GAP  
BURNER WITH WELDED INSIDE THE PIPE IS TIGHTENED

4

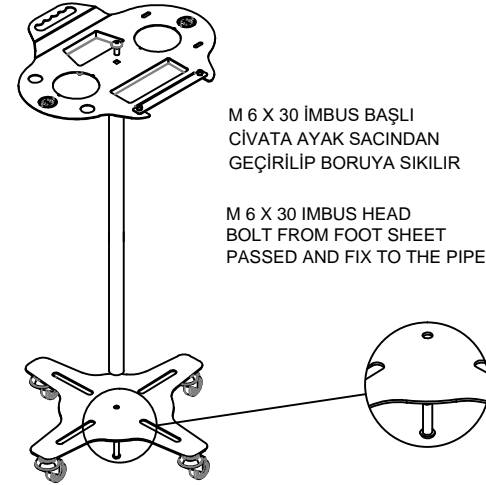

M 6 X 30 İMBUS BAŞLI  
CİVATA AYAK SACINDAN  
GEÇİRİLİP BORUYA SIKILIR

M 6 X 30 İMBUS HEAD  
BOLT FROM FOOT SHEET  
PASSED AND FIX TO THE PIPE



ÜRÜN ADI:  
Name of product: OZZY ALU BOYA ARABASI MONTAJ ŞEMASI / ASSEMBLY DIAGRAM

ÇİZEN:  
Designer: BİLAL CENGİZ

TARİH:  
Date: 27.01.2021

ÖLÇÜLER : cm (santimetre'dir)  
Çizim üstünden ölçü alınmamalıdır.  
Measurements are in cm.